



Three Phase TC Series Circuit Breakers

Miniature Ambient Compensated

Features

- **One phase trips all**
- **Protective shields between each phase's terminals**
- **Pads increase mounting stability**
- **Also includes identical features as 2TC and 3TC**



Overview

The 6TC and 9TC circuit breakers provide ambient compensated circuit protection in a lightweight, subminiature package size. The three phase design integrates each individual phase to provide overcurrent protection in the event of simultaneous or unbalanced overloads, including short circuit conditions.

Coordination

The 6TC and 9TC are compatible with their single phase 2TC and 3TC cousins. The 6TC and 9TC are available in ratings from 1-35 amps, with military and various commercial approvals on most styles.

Ambient Temperature Compensation

The 6TC and 9TC are ambient compensated circuit breakers. This allows usage of smaller gauge wire.

The 6TC and 9TC can operate over a temperature range of -54°C to 121°C , however, care should be taken to understand the specification limits at elevated ambient temperatures.

Options*

- Longer push buttons
- High vibration
- Metric mounting thread
- Metric terminal thread
- Dust boot†
- Auxiliary switch device available††

* Contact factory for details

† Part Number 14500-1 fits 15/32 bushing
Part Number 14500-5 fits 7/16 bushing

†† 6TC Device

Trip Free

The complete line of TC series circuit breakers is trip free. The circuit breaker cannot be maintained closed during an overload, even with the actuator button held closed.

High Short Circuit Capacity

For its miniature size, the 6/9TC series offers unusually high current interrupting capacity. Overloads up to 2000 amps at 120 VAC, 400 Hz can be safely interrupted without affecting calibration or operating performance in the standard 6/9TC series.

Qualifications

MS14154	6TC2
MS14154L	6TC37
MS14154V	6TC63
MS14153	9TC2

European standards

SAE standards

All U.S. aircraft OEM's

Most European aircraft OEM's

Characteristics

6/9TC

6TC14

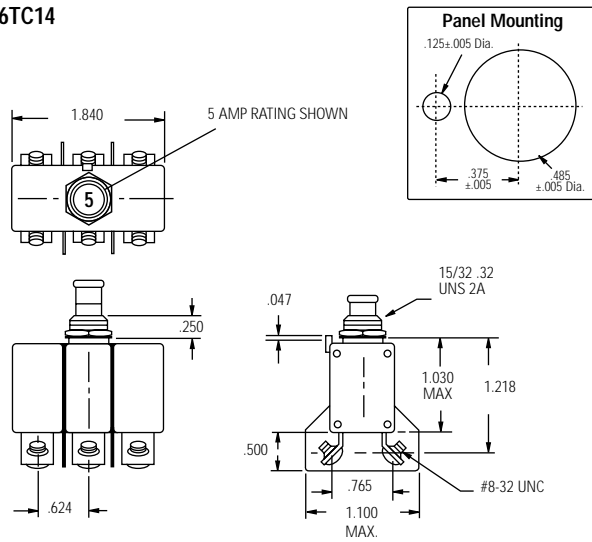

9TC14

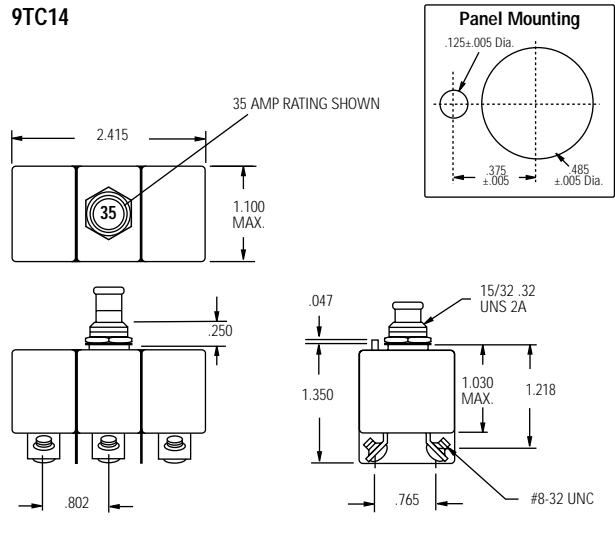

Calibration: 2-20 amps

TEMP °C	MIN ULT TRIP	MAX ULT TRIP	TRIP TIME - SECONDS		
			200%	500%	1000%
+25	110%	145%	4-20	.40-2.0	.10-.53
-54	110%	165%	6-40	.55-3.5	.15-.80
+90	100%	145%	3-20	.33-1.7	.08-.40
+121	90%	145%	3-20	.33-1.7	.08-40

† Single phase max. ult. trip values apply with other two phases carrying 100% of rated current.

Vibration*	10 G's minimum, 50-500 Hz
Mechanical Shock	50 G's
Acceleration	10 G's
Weight	6TC14 - 65 gm max. 9TC14 - 110 gm max.

Interrupt Current

2-20 amps: 2000 amps at 120 VAC, 400 Hz
1, 15-35 amps: 2000 amps at 120 VAC, 400 Hz

Endurance

2500 cycles 120 VAC, 400 Hz Inductive
5000 cycles 120 VAC, 400 Hz Resistive
5000 cycles Mechanical, no load

* Other vibration levels available. Contact factory for details.

Calibration: 1, 15-35 amps

TEMP °C	MIN ULT TRIP	MAX ULT TRIP	TRIP TIME - SECONDS		
			200%	500%	1000%
+25	110%	145%	4-20	.40-2.0	.10-.53
-54	110%	165%	6-40	.55-3.5	.15-.80
+90	100%	145%	3-20	.33-1.7	.08-.40
+121	90%	145%	3-20	.33-1.7	.08-40

† Single phase max. ult. trip values apply with other two phases carrying 100% of rated current.

TI Number	Voltage Drop (max.)
6TC14-2	0.70
6TC14-2½	0.50
6TC14-3	0.40
6TC14-4	0.37
6TC14-5	0.35
6TC14-7½	.192
6TC14-10	.176
6TC14-15	.176
6TC14-20	.176

TI Number	Voltage Drop (max.)**
9TC14-1	1.10
9TC14-15	0.25
9TC14-20	0.25
9TC14-25	0.25
9TC14-30	0.25
9TC14-35	0.25

** Max voltage drop at nominal rated current.
(25 amp 6TC pending qualification.)

Approximate Time-Current Curves - 6TC and 9TC Circuit Breakers

