



## Klixon® | 3MP Self-Hold MOTOR PROTECTOR

### KEY BENEFITS

Provides higher level of safety for appliances having free access to rotating parts

Minimizes the total cost of the motor protection function

Guarantees to pass the UL 18 days locked rotor test in combination with high currents

Provides mounting flexibility

Assures maximum protection under locked rotor conditions

Sensata Technologies Engineering knowledge base

European supply

Recent history has seen a growing demand for a non-self resetting motor protection device to ensure a high level of safety. Sensata Technologies has developed the self hold motor protector for both 120 & 250 Vac applications in a wide current range.

#### Design & operating principles

The heart of the 3MP self hold consists of the pre-set Klixon® snap action bimetallic disc welded into a metal housing with integrated terminal. The housing is covered by the plate on which a heater can be welded to increase the current sensitivity of the device. A PTC pill is mounted on top of the metal housing by a clip to meet the requirements for self hold.

The combination of a variety of standard terminal configurations and carefully selected materials provides easy handling and mounting. Customized terminal configurations are available on request. Wires including connectors can be automatically attached to the standard crimp terminals.

Sensata Technologies supplies a range of standard leads configurations; customized solutions are available on request.

In construction where the 3MP self hold device is contacting conductive parts of the motor assembly, Sensata Technologies can deliver the self hold devices with a Mylar™ insulation sleeve. Customized coding and coloring is an option on request.

The operating principle of the 3MP self hold is both simple and effective. The protector is actuated by current passing through it and by the heat received from surrounding parts.

The electrical circuit is interrupted when the disc reaches its pre-set open temperature. Due to the heat supply from the PTC pill, the bimetal disc does not cool down below the close temperature. The contacts will remain open until the appliance switched off by the user, assuring a higher level of safety. When switched off the device cools down to a safe temperature again and the contacts will automatically reset. The bimetal disc provides excellent thermal and current sensitivity in overload situation. Under locked rotor conditions the integrated heater in combination with the bimetal disc provide very accurate trip times for maximum protection.

#### Applications

The 3MP self hold is used in domestic and industrial electric motors for washers, vacuum cleaners, chain saws, trimmers, lawn mowers and pumps in the 120 and 250 Vac applications.

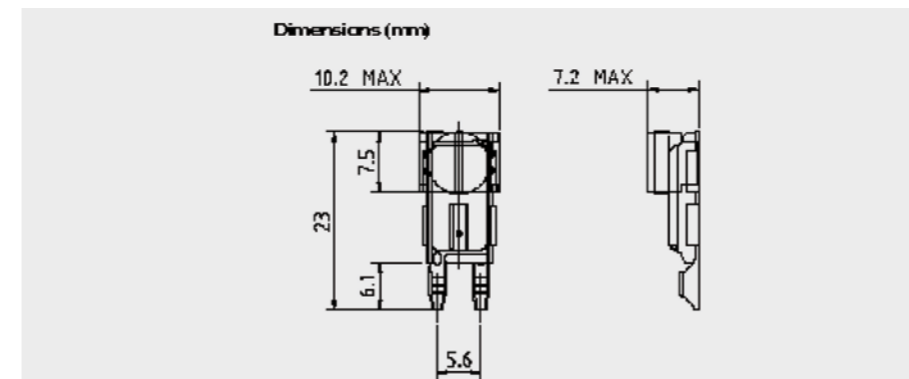

The curves of First Cycle Tripping time and Ultimate trip current are meant to be for selecting samples to perform verification tests only. In the figures two curves of a wide range of possibilities are shown. The level and slope can be varied by making an other selection for the pre-set temperature, bimetal disc and/or heater.

#### Specifications

Standard operating temperature range	from 80°C - 170°C (Increments 5K)
Tolerance on open temperature	± 8K
Max. Ambient temperature	T-open +20°C
Ambient temperature to guarantee stable Self Hold function	0°C
Peak temperature (5 min)	200°C
Time check at T-ambient 25°C	4 to 10 seconds depending on current level
Contact rating	18 A @ cos 0.6 / 250Vac / 300 cycles

#### Declarations

Declarations to EN60730-2-2	
Purpose of the control.....	Thermal Motorprotector
PTI of insulation materials.....	PTI 175
Method of mounting.....	Off-winding, fixed position, no mounting limitation
Type of action.....	Type 3C
Reset characteristic.....	- Automatic - Voltage maintained by PTC heater. Device resets by interrupting power supply
Control pollution degree.....	Degree 1

#### Certifications

Agency	File number	Standard
ENEC	2014531.07	EN60730-2-2 Thermal motor protector
UL / C-UL	E15962	UL2111 / CSA C22.2 No. 77

