

Klixon® | 7895 SERIES **MOTOR THERMOSTATS** *Hermetically Sealed On-Winding*

CONSTRUCTION

The basic element in the on-winding motor thermostat is the Klixon® snap-acting disc. The electrical circuit consists of the pin, insulated from the case by the glass-to-metal seal, connected to the stationary contact through the disc to the case. In the 7895 thermostat, the metal case is electrically hot and requires some method of insulation from the motor windings. Several custom configurations of insulation and terminations are available at slight additional cost.

Features & Benefits

- Small size and shape permits close coupling to motor windings for increased protection
- Hermetically sealed enclosure
- Simple, rugged all-welded construction has one moving part for trouble-free service
- Klixon® snap action thermal disc assures positive make and break action controlled temperature differential aid vibration resistance

Klixon® 7895 on-winding motor thermostats are designed to protect hermetically-sealed compressor motors from excessive winding temperatures. A positive refrigerant seal combined with small tubular construction allows these thermostats to be installed directly in the motor windings for precise monitoring of winding temperatures. As a result, the compressor manufacturer can choose a thermostat that will allow the motor to be safely rated to its maximum capacity.

Installation

Maximum heat transfer from the motor windings to the thermostat is the key to optimum performance. In many cases, the total surface of the device can be utilized by inserting its entire length within the stator winding. Good performance is also achieved by lacing the protector to the top of the windings, making sure that the surface of the case is in close contact with the stator windings. The thermostat may be varnished dipped and baked with the entire assembly.

Pilot Circuit Operation

The 7895 thermostat is used as a pilot duty control to protect a motor from overheating in a running overload condition. When used alone, it cannot protect against locked rotor since its response time is not fast enough to follow the very rapid temperature rise of the windings. The Klixon 8347 and 8348 supplementary overloads with their quick response to locked rotor current, can be used to supplement the 7895 thermostat. These overload devices trip very quickly for the first several cycles, allowing enough time for the heat generated in the windings to reach the thermostat which then takes over as the controlling element. This combination is used to protect both single-phase and three-phase motors.

Dimensions

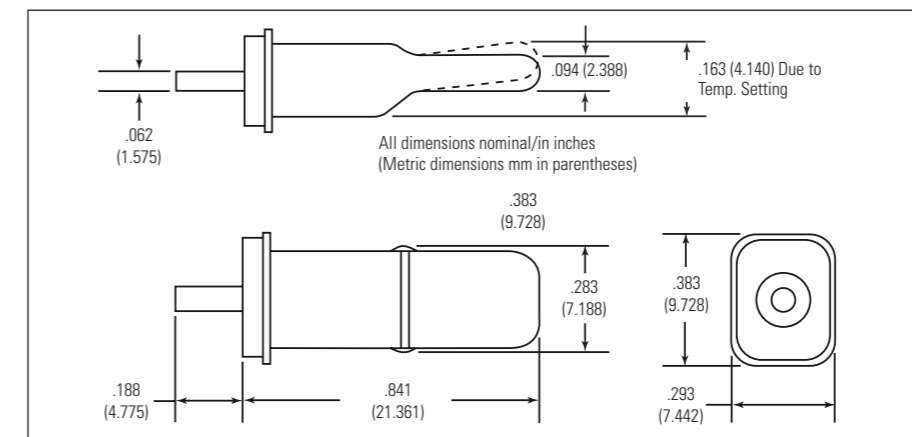

Wire Lead Insulations

Dacron Mylar Dacron

600V – 105°C temperature rating – 18 AWG

Dacron Teflon Mylar Dacron

600V – 105°C temperature rating – 20 AWG

Teflon

300/600V – 200°C temperature rating – 22 AWG

Teflon

300V – 200°C temperature rating – 18 AWG

Mylar over Teflon – .007" thick

(.004" Mylar/.003" Teflon)

Terminations

Female flag quick connect 1/4" open end terminal for #10 screw, #10 eyelet

UL and CSA Rated

125 VA, 24 VAC

345 VA, 110-600 VAC

(limited to the lead wire voltage rating if less than 600 VAC).

Insulation Sleeve Material

Mylar – .004" thick

Typical Custom Configurations



Operating Temperatures

75°C to 135°C

Standard Tolerances

±5°C open, ±11°C close

Standard Differential

22°C nominal

Special Tolerances

±3°C open, ±5°C close

Special Differential

17°C nominal

VDE approved
7895-XXX-XXX

$\frac{2}{250}$ (2) \sim $\frac{1}{380}$ (1) \sim $\frac{5.2}{24}$ (5.2)

Class 1, T200

Engineering Test Samples

To order test samples please supply the following information:

1. Opening temperature
2. Temperature differential
3. Tolerances desired on opening and closing temperatures
4. Voltage
5. Lead type, size and length
6. Insulation required

Coding System

