



FEATURES

- Robust High Voltage/High Power load break bi-directional DC contactor
- Designed for high voltage Power conversion equipment OEM's: Photovoltaic/Battery inverters, battery pack designers, DC combiner boxes and other HVDC industrial drive systems
- Excellent isolation performance: 10kv withstand between open contacts for critical safety applications
- Mechanically linked SPDT auxiliary contacts for critical safety applications. Reliable indication of the main contacts in the closed position
- Hermetically Sealed - Exceeds IP67-69 specifications. No exposed arcing to open air environments. Designed to meet UL1604 for hazardous locations.

PRODUCT SPECIFICATIONS

Specifications	Units	Data
Contact Arrangement (main)	Form X	SPST-NO
Contact Arrangement (auxiliary)	Form C	SPDT
Mechanical Life (main)	cycles	100,000
Auxiliary Contact Load Life (3A @ 24Vdc) ⁴	cycles	100,000
Contact Resistance ¹		
Max @ rated carry current	mohms	0.3
Typical @ rated carry current	mohms	0.15
Operate time, 25°C		
Close (includes bounce) Max	ms	85
Close (includes bounce) Typical	ms	70
Release time (includes arc time at max. break current)	ms	70
Insulation Resistance ²	Mohms	100
Dielectric at sea level (leakage < 1mA)	V	5,375
Impulse Withstand Voltage (per IEC 61000-4-5)	kV	10
Voltage Withstand (open contacts, 1 min. <1mA leakage)	kV	10
Shock, 1/2 Sine, 11ms	G peak	10
Vibration, Sinusoidal (500-2000 Hz peak)	G	10
Operating ambient Temp Range	°C	-55 to +85
Storage ambient Temp Range	°C	-70 to +125
Weight, Typical	Kg (Lb)	4.17 (9.2)
Environmental Seal	Exceeds IP67 & IP69K	
Salt Fog	MIL-STD-810	

COIL RATINGS

Coil P/N Designation	B	C
Coil Voltage Nominal	12 VDC	24 VDC
Coil Voltage Max	14 VDC	30 VDC
Pick-up, Volts, Max	8 VDC	16 VDC
Drop-out, Volts, Max	3.7 VDC	7.5 VDC
Coil Current ³	1.25 A	0.63 A
Coil Power ³	15 W	15.1 W
Internal Coil Suppression	TVS 	
Coil Back EMF	55 V	
Transients, Max (13 ms)	±50 V	

POWER SWITCHING CYCLES

Make & Break	CYCLES
400A @ 1,500VDC	5,000 ²
500A @ 1,200VDC	5,000 ²
600A @ 1,000VDC	5,000 ²

CONTINUOUS CARRY CURRENT @ 85°C Ambient

Current	Conductor
400A ⁵	400mcm/203mm ²
600A ⁵	600mcm/304mm ²
1,000A ⁵	1,273mcm/633mm ²

FAULT INTERRUPT

Break Only	Iterations
1,500A @ 1,250VDC	10
2,700A @ 1,000VDC	2
5,000A @ 400VDC	5

MAX CLOSING CURRENT

Make Only	Iterations
8,000A @ 24VDC	10
6,000A @ 1,000VDC	2
1,000A @ 24VDC	10,000

SHORT CIRCUIT WITHSTAND

Closed Contacts	Iterations
8,000A / 50ms	10
10,000A / 2ms	3

DIMENSIONS

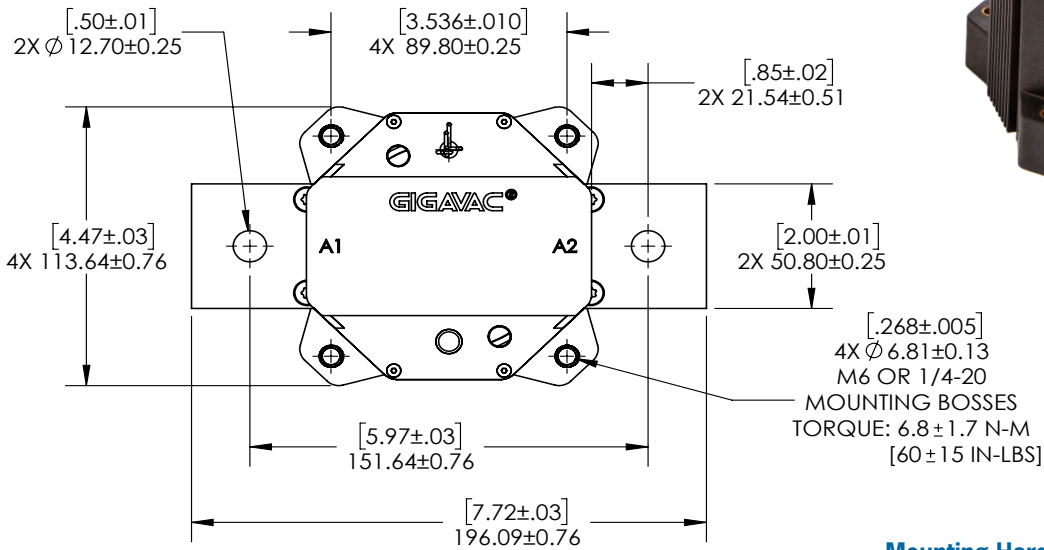

Mounting Hardware (customer supplied)

M6 or 1/4-20
Torque: 6.8 Nm (60 in-lb)

Power Connections

Nickel plated copper busbars

Case Material

DuPont Zytel FR50
(25% glass filled nylon)

Coil Wire / Aux Wire

M22579/43-22, 22AWG

Power Contacts

(Contacts & coil not polarity sensitive)

Auxiliary Contacts

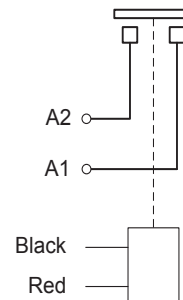
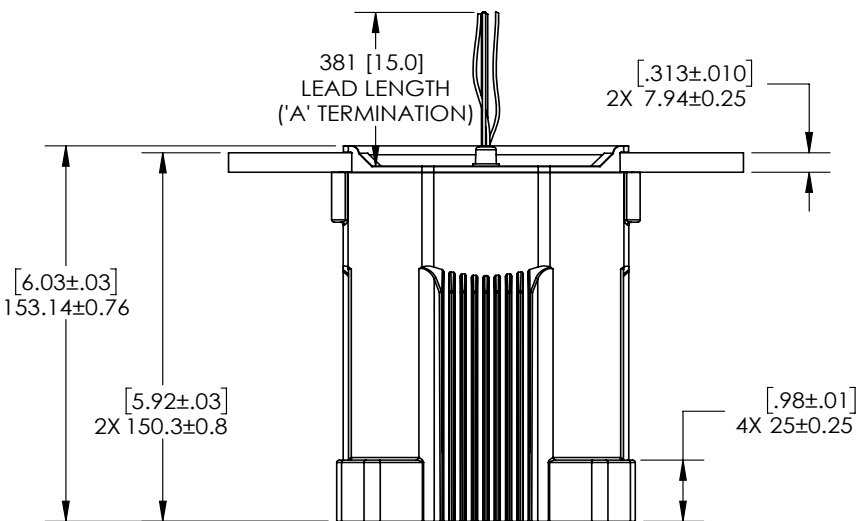
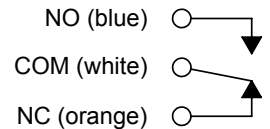

PART NUMBER SYSTEM

HX460	B	A	A
Coil Voltage	B = 12 Vdc, continuous duty coil, internal coil suppression		
	C = 24 Vdc, continuous duty coil, internal coil suppression		
Coil Termination		A = Flying leads 38 cm (15 in)	
		F = Molex 5-pin Connector 39-01-4050, lead length 28 cm (11 in)	
Auxiliary Contact			A = SPDT

Notes & Definitions:

- 1 Contact resistance measured at currents $\geq 100A$.
- 2 Insulation resistance is 50 Mohms after life.
- 3 Coil ratings are listed for continuous duty operation. External PWM economization can be used following instructions in Applications Note [AN-019](#). Contactor is operated by a coil that changes resistance with temperature. See Applications Notes [AN-020](#) and [AN-030](#) for coil versus temperature graphs.
- 4 Minimum current is 0.1mA, 5V. The auxiliary contact is mechanically linked to the main power contacts.
- 5 Continuous currents assume a 65°C rise on the power terminals. Customer must limit terminal temperature to 150°C continuous.

APPLICATION NOTES

- Contactors feature internal transorb for coil suppression. For continuous duty coil operation, no external diodes should be added across the coil. The use of additional external coil suppression can slow the release time and invalidate the life cycle ratings, or can cause the contactor not to be able to interrupt the maximum current specified. If lower coil back EMF is required, please contact GIGAVAC for assistance.
- Applications with capacitors will require a pre-charge circuit. [Click here](#) for more information.
- Electrical life rating is based on resistive load with 27 μ H maximum inductance in circuit. Because your application may be different, we suggest you test the contactor in your circuit to verify life is as required.
- End of life is defined as when the dielectric, insulation resistance or contact resistance exceeds the specifications listed.
- Main power contacts (A1, A2) are not polarity sensitive.