



FEATURES

- Designed for EV applications that require high continuous currents and/or high short circuit withstanding.
- Smallest and lightest 600A contactor on market.
- Hermetically Sealed – Designed to meet: UL1604 for Class I & II, Div 2 and Class III for use in hazardous locations, IP67 for temporary water immersion for 30 min, SAE J1171 - external ignition protection, and ISO8846 for protection against ignition around flammable gasses.
- Stainless steel nuts and brass mounting inserts, for years of corrosion free service.
- Not position sensitive – can be mounted in any position for ease of installation.

PRODUCT SPECIFICATIONS

Specifications	Units	Data
Contact Arrangement (main)	Form X	SPST-NO
Mechanical Life	cycles	200,000
Contact Resistance		
Max @ rated carry current	mohms	0.25
Typical @ rated carry current	mohms	~0.16
Operate time, 25°C		
Close (includes bounce) Max	ms	26
Close (includes bounce) Typical	ms	20
Release time (includes arc time at max. break current)	ms	10
Insulation Resistance¹	Mohms	100
Dielectric at sea level (leakage < 1mA)	VRMS	2,200
Shock (open), 1/2 sine 11msec	Gs	25
Shock (actuated)	Gs	50
Vibration, Sinusoidal (50-2000 Hz peak)	Gs	25
Operating ambient Temp Range²	°C	-55 to +85
Storage ambient Temp Range	°C	-70 to +150
Weight, typical without nuts and washers	Kg (Lb)	0.475 (1.05)
Short Circuit Current (20ms)	A	5000
Max Break Current		
400V	A	3200
800V	A	1500

COIL RATINGS at 25°C

Coil P/N Designation	M	P ¹
Coil Voltage, Nominal	12/24 VDC	12/24 VDC
Coil Type	Internal PWM	External PWM ³
Pick-Up Voltage, Max	9.8 VDC	7.0 VDC
Drop-Out Voltage	7.0 VDC	2.0 VDC
Coil Resistance	4.2 ohms +/- 5%	4.2 ohms +/- 5%
Hold Voltage	N/A	3.6 - 4.7 VRMS
Inrush Time, Max	100 msec	100 msec

POWER SWITCHING AND CURRENT CARRY RATINGS

DC POWER SWITCHING CYCLES

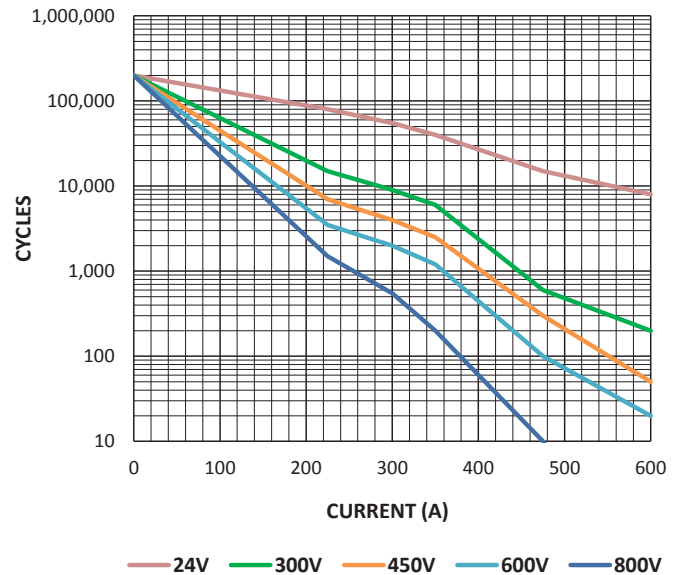

CURRENT CARRY vs TIME with 85°C terminal temperature rise

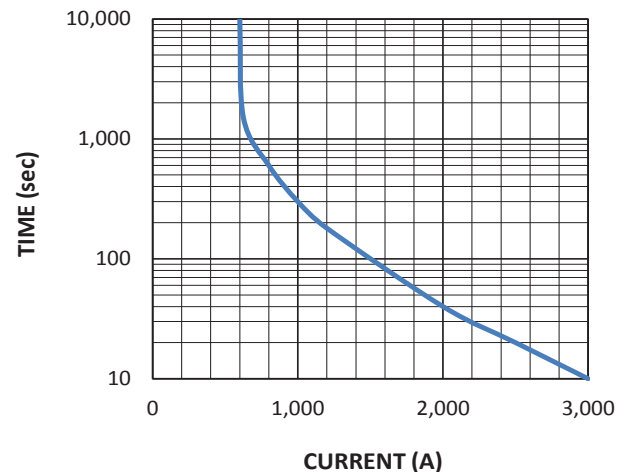

DIMENSIONS



Coil Termination

JST Connector: 02CPT-B-2A
JST Terminal: SCPT-A021GF-0.5

Mounting

M5 or No. 10 Screws
Torque 1.7-4 Nm [15-35 in-lb]

Power Connection

Stainless, nickel plated M8x1.25 stud
Stainless M8x1.25 flanged nut
Torque 10 Nm [90 in-lb] max

Power Contacts

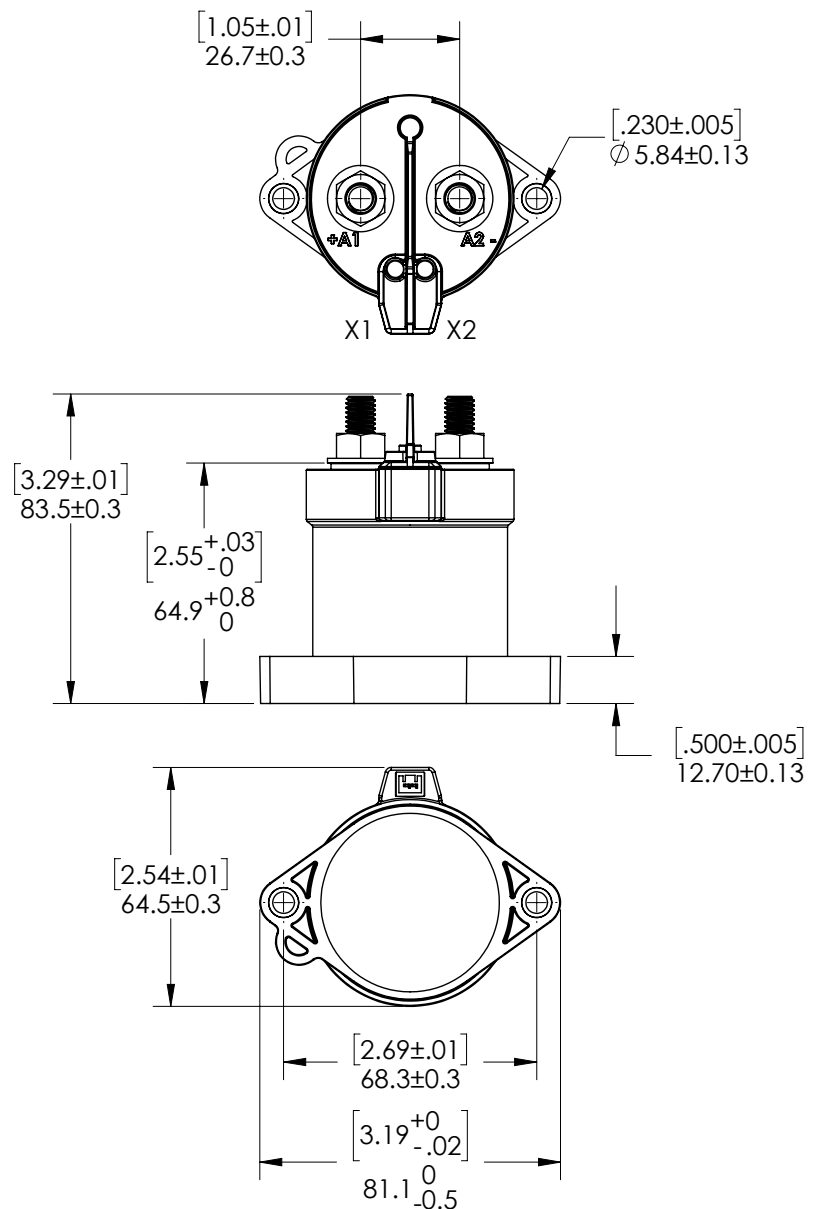
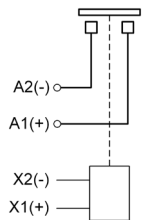

PART NUMBER SYSTEM

GXV611	P		
Coil Voltage	M = 12/24 Vdc, Internal PWM		
	P = 12/24 Vdc, External PWM ³		
Coil Termination		JST Connector	
Auxiliary Contacts			None

Notes & Definitions:

- 1 50 Mohms after life.
- 2 Contactor can operate up to 125°C ambient in special cases - contact GIGAVAC for details. Limit terminal temperature to 175°C.
- 3 Customer must provide an external economizer that meets the Pick-up Current, Coil Current, and Pick-up Current Time. Contact GIGAVAC for information on external PWM.

APPLICATION NOTES

- [No external diodes](#) should be added across the coil.
- Power switching lifecycles are based on [current flow](#) from A1(+) to A2(-). For best breaking performance, the contactor should be installed so that current flows from A1(+) to A2(-). There are cases where the contactor will interrupt power in the opposite direction but please contact GIGAVAC to confirm suitability. Direction of current flow is not relevant during make or when flowing on closed contacts. For bi-directional contactors, please contact GIGAVAC.
- Applications with [capacitors](#) will require a pre-charge circuit.
- Electrical life rating is based on resistive load with 27µH maximum inductance in circuit. Because your application may be different, we suggest you test the contactor in your circuit to verify life is as required.
- End of life is defined as when the dielectric, insulation resistance or contact resistance exceeds the specifications listed.



Authorized Sales Rep.

59 Rue Emile Deschanel, 92400
 Courbevoie, France

contact@jbcontrols.com

Tel: + 33 (0)1 46 91 93 30

www.jbcontrols.com - www.jbc-aero.com